

# A2F

## COMPRESSION GLAND for Unarmoured Tray Cable

### Features and Benefits

- Gland for use in Ordinary and Hazardous Locations.
- Fitted with a specially formulated elastomeric displacement seal, giving superior cable retention, explosion protection and IP rating.
- Precision manufactured from high quality brass (Marine Grade Electroless Nickel Plated™) available in aluminium or stainless steel 316/316L on request. (Note: Aluminium not suitable for Group I applications.)
- Supplied with a thread sealing gasket.



### Technical Data

Type:	A2F
Gland Material:	Brass (Marine Grade Electroless Nickel Plated™), Aluminium or Stainless Steel 316/316L
Seal Material:	Standard Thermoset Elastomer or Extreme Temperature Seals
Sealing Gasket Material:	HDPE, Nylon 66 or PTFE
Cable Type:	Unarmoured Tray Cable
Sealing Area:	Outer Sheath
Optional Accessories:	Adaptor, Reducer, Earth Tag, Locknut, Serrated Washer and Shroud
Note:	The installer should ensure that the materials are suitable for the installation environment.

### Temperature Range

When fitted with sealing gaskets the temperature range for the gland will be:-  
 Sealing gasket material: Standard Seals: -60°C and +95°C/100°C(HDPE/Nylon Sealing Gasket)  
 Extreme Temp. Seals: -60°C and +160°C (PTFE Sealing Gasket)

### Certification Details

Equipment Protection Levels:	NEC / CEC: Class I Div. 2 Gr ABCD, Class II Div. 2 Gr FG, Class III Division 2 Ex db IIC Gb, Class I Zone 1 AEx eb IIC Gb / Ex eb IIC Gb Zone 21 AEx ta IIIC Da / Ex ta IIIC Da, Class I Zone 2 AEx nR IIC Gc / Ex nR IIC Gc, IP66/67/68, IP65, Type 4X IECEX: Ex db eb I Mb, Ex db eb IIC Gb, Ex nR IIC Gc, Ex ta IIIC Da	
Conformance:	Standard:	Certify:
CEC	CSA C22.2 No. 18.3-12, 174:2018 & 213:2017	E115594
NEC	CSA C22.2 No. 60079 - 0, 1, 7, 15, 31	
IECEX	UL514B, UL121201 UL 60079 - 0, 7, 15, 31 IEC 60079 Part 0, 1, 7, 15, 31	IECEX TSA 23.0026
IP66/67/68 850m - Parallel	IEC60529	CML 15Y728
IP68 - Tapered and approved grease	IEC 60529	IECEX TSA 23.0026
Nema Type 4X	NEMA 250	E115594
Deluge Protection	DTS-01	CML 14CA370-2
Corrosion Protection	ASTM B117-11, BS EN ISO 3231	EXOVA N968667
Marine ABS	IEC/EN 60079 - 0, 1, 7, 15, 31	ABS 20-1952706-1-PDA
DNV	IEC/EN 60079 - 0, 1, 7, 15, 31	TAE0000010
EMC Compatible	EN 55011, + A1, EN 55022	SGS EMC305079/1

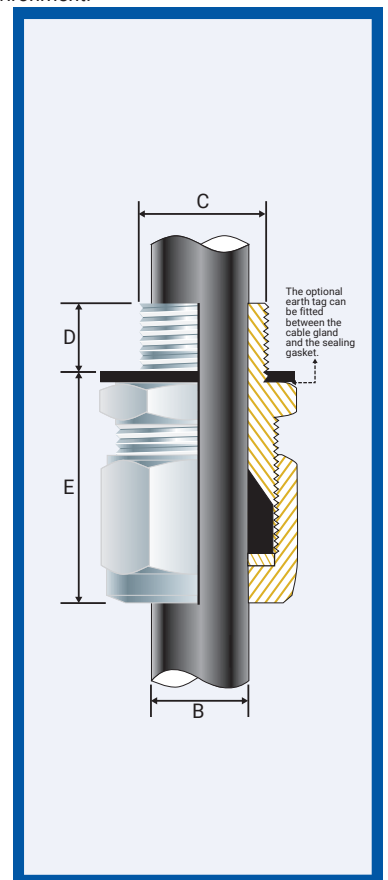

### Conditions for Safe Use - X

- The cable gland sizes under M20 / ¾" NPT and under shall only be used on fixed installations where the cable is clamped, or stress applied to the cable gland is prevented.
- According to IEC 60079-14, 10.6.2: An Ex d gland will only maintain Ex d integrity when used with substantially round, compact and filled cable. If not a CCG VORTEX® barrier gland should be used.

### NPT Entry Thread

Gland Size Ref	Product Code	NPT Entry Thread		Alternative Thread Product Code	NPT Entry Thread		Cable Detail		Maximum Length 'E'	Hexagonal Detail	
		'C'	Min 'D'		'C'	Min 'D'	Min 'B'	Max 'B'		Max 'Flats'	Max 'Crns'
00-20ss	054100-012NPT-MNA	½	0.590	054100-034NPT-MNA	¾	0.590	0.118	0.335	0.984	0.945	1.063
0-20s	0541-0-012NPT-MNA	½	0.590	0541-0-034NPT-MNA	¾	0.590	0.275	0.472	0.984	0.945	1.063
1-20	054101-012NPT-MNA	½	0.590	054101-034NPT-MNA	¾	0.590	0.433	0.590	1.181	1.063	1.181
2s-25s	054122-034NPT-MNA	¾	0.590	054122-001NPT-MNA	1	0.748	0.453	0.689	1.181	1.377	1.535
2-25	054102-034NPT-MNA	¾	0.590	054102-001NPT-MNA	1	0.748	0.590	0.787	1.181	1.377	1.535
3s-32s	054133-001NPT-MNA	1	0.748	054133-114NPT-MNA	1¼	0.748	0.630	0.866	1.181	1.653	1.850
3-32	054103-001NPT-MNA	1	0.748	054103-114NPT-MNA	1¼	0.748	0.787	1.043	1.181	1.653	1.850
4s-40s	054144-114NPT-MNA	1¼	0.748	054144-112NPT-MNA	1½	0.826	0.866	1.240	1.495	2.046	2.322
4-40	054104-114NPT-MNA	1¼	0.748	054104-112NPT-MNA	1½	0.826	1.023	1.338	1.495	2.046	2.322
5s-50s	054155-112NPT-MNA	1½	0.826	054155-002NPT-MNA	2	0.826	1.141	1.495	1.810	2.558	2.873
5-50	054105-112NPT-MNA	1½	0.826	054105-002NPT-MNA	2	0.826	1.338	1.751	1.810	2.558	2.873
6s-63s	054166-002NPT-MNA	2	0.826	054166-212NPT-MNA	2½	1.181	1.495	1.968	2.046	3.148	3.542
6-63	054106-002NPT-MNA	2	0.826	054106-212NPT-MNA	2½	1.181	1.751	2.224	2.046	3.148	3.542
7s-75s	054177-212NPT-MNA	2½	1.181	054177-003NPT-MNA	3	1.259	1.968	2.440	2.125	3.778	4.250
7-75	054107-212NPT-MNA	2½	1.181	054107-003NPT-MNA	3	1.259	2.204	2.656	2.125	3.778	4.250
8-80	054108-003NPT-MNA	3	1.259	-	-	-	2.125	2.715	2.676	3.778	4.250
9s-90s	054199-003NPT-MNA	3	1.259	054199-312NPT-MNA	3½	1.299	2.361	2.952	2.755	4.368	4.919
9-90	054109-003NPT-MNA	3	1.259	054109-312NPT-MNA	3½	1.299	2.873	3.207	2.755	4.368	4.919
10-10	054110-312NPT-MNA	3½	1.299	054110-004NPT-MNA	4	1.338	3.188	3.621	2.755	4.919	5.549
11-110	054111-004NPT-MNA	4	1.338	-	541	-	3.581	3.975	2.755	5.313	5.982

All dimensions are in inches. NPT threads should be tightened 'wrench tight'

# FITTING INSTRUCTIONS

## Metric Entry Thread

Gland Size Ref	Product Code	Metric Entry Thread		Cable Detail		Maximum Length 'E'	Hexagonal Detail		Tightening Torque Nm/lb ft
		'C'	Min 'D'	Min 'B'	Max 'B'		Max 'Flats'	Max 'Crns'	
00-20ss	054100-MNA	M20x1.5	0.591	0.118	0.335	0.984	0.945	1.063	33/24
0-20s	0541-0-MNA	M20x1.5	0.591	0.276	0.472	0.984	0.945	1.063	33/24
1-20	054101-MNA	M20x1.5	0.591	0.433	0.591	1.181	1.063	1.181	33/24
2s-25s	054122-MNA	M25x1.5	0.591	0.453	0.689	1.181	1.378	1.535	48/35
2-25	054102-MNA	M25x1.5	0.591	0.591	0.787	1.181	1.378	1.535	48/35
3s-32s	054133-MNA	M32x1.5	0.591	0.630	0.866	1.181	1.654	1.850	55/41
3-32	054103-MNA	M32x1.5	0.591	0.787	1.043	1.181	1.654	1.850	55/41
4s-40s	054144-MNA	M40x1.5	0.591	0.866	1.240	1.496	2.047	2.323	65/48
4-40	054104-MNA	M40x1.5	0.591	1.024	1.339	1.496	2.047	2.323	65/48
5s-50s	054155-MNA	M50x1.5	0.591	1.142	1.496	1.811	2.559	2.874	83/61
5-50	054105-MNA	M50x1.5	0.591	1.339	1.752	1.811	2.559	2.874	83/61
6s-63s	054166-MNA	M63x1.5	0.591	1.496	1.969	2.047	3.150	3.543	98/72
6-63	054106-MNA	M63x1.5	0.591	1.752	2.224	2.047	3.150	3.543	98/72
7s-75s	054177-MNA	M75x1.5	0.591	1.969	2.441	2.126	3.780	4.252	116/85
7-75	054107-MNA	M75x1.5	0.591	2.205	2.657	2.126	3.780	4.252	116/85
8-80	054108-MNA	M80x2.0	0.787	2.126	2.717	2.677	3.780	4.252	120/89
9s-90s	054199-MNA	M90x2.0	0.787	2.362	2.953	2.756	4.370	4.921	120/89
9-90	054109-MNA	M90x2.0	0.787	2.874	3.209	2.756	4.370	4.921	120/89
10-10	054110-MNA	M100x2.0	0.787	3.189	3.622	2.756	4.921	5.551	120/89
11-110	054111-MNA	M110x2.0	0.787	3.583	3.976	2.756	5.315	5.984	175/129
12-120	054112-MNA	M120x2.0	0.787	3.976	4.291	2.756	5.512	6.220	175/129
13-10	054113-MNA	M130x2.0	0.787	4.291	4.567	2.756	5.748	6.457	175/129

Dimensions are in inches

## FITTING INSTRUCTION

### ENCLOSURES AND EQUIPMENT TO WHICH CABLE GLANDS ARE FITTED:-

- Must be made from materials which are compatible with the cable gland materials.
- Have a sealing area around the cable gland entry point with a surface roughness <math>< Ra 6.3 \mu m</math>.
- Have entries that are perpendicular to the enclosure face in the area where the cable gland will seal to within 2.5°.
- Are sealed using the supplied sealing gasket (parallel threads) or by fully tightening into a threaded entry (tapered threads). Note that for tapered threads the IP rating can be improved to IP68 with the use of a suitable thread sealant.

### MUST HAVE THREADED ENTRIES

- The same thread size as the cable gland. (Thread adapters should be used to correct

any mismatch).

- With a thread tolerance of metric class '6H' or equivalent.
- Where the thread length is a minimum of 15mm for AEx d / Ex d applications.

### OR CLEARANCE HOLES (not Ex d)

- Where the hole size is the thread nominal size with a tolerance of +0.1 to +0.7mm. (e.g. the clearance hole for an M20 thread will have a diameter between 20.1mm and 20.7mm).
- Through material that is between 1mm and 12mm thick. (Thicker materials can be accommodated using glands with extended entry threads.)

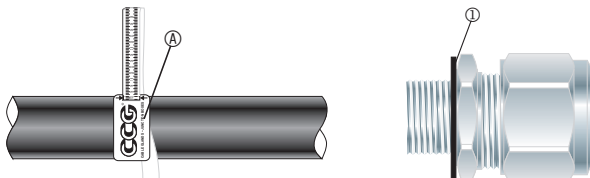

1. For accurate sizing, use a CCG Dimension Tape (A) on the cable sheath. To maintain IP66/68, ensure the gasket (1) is in place.

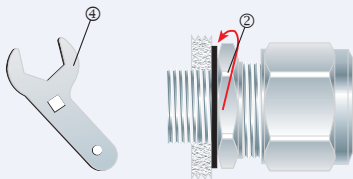

2. Screw the inner (2) into the apparatus. Tighten the inner (2) to the installation torque using a CCG Spanner (4).

If the gland has NPT entry threads fitted to a threaded entry then IP68 (2m) can be achieved by applying one of the following tested and approved grease types to the thread:- Renolit Lubrene CA700 or LX220 EP2, Renolit LC-WP2 or Moly LX2, or Dow Corning 4 Electrical Compound.

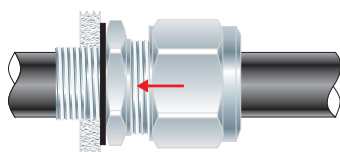

3. Pass the cable end through the gland assembly.

Alternative installation through an unthreaded entry.

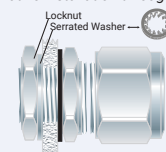

If the apparatus is untapped use a locknut.

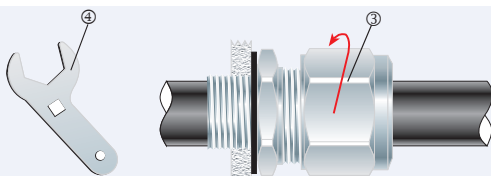

4. Tighten the outer nut (3) to the installation torque using a CCG Spanner (4) to produce a seal and grip on the cable.

YouTube Instruction Video: <http://youtu.be/3Mo-Utop3AY>