

Ex CORROSION GUARD®

CABLE GLAND for Steel or Aluminium Wire Armoured Tray and Marine Shipboard Cable

Features and Benefits

- Gland for use in highly corrosive areas of Ordinary and Hazardous Locations.
- Factory fitted captive elastomeric seals for Built-in Safety™.
- Two-part handling, freely rotating captive cone and inspectible cone ring provides an armour clamp and earth bond on steel wire and aluminium armour.
- Corrosion Guard® screws onto the gland body and seals over the outer sheath of the cable giving an IP68 and deluge proof seal protecting the armour and metal parts of the gland.
- Precision manufactured from high-quality brass (Marine Grade Electroless Nickel Plated™).
- Complete with thread sealing gasket.



Technical Data

Type:	Ex Corrosion Guard®
Gland Material:	Brass (Marine Grade Electroless Nickel Plated™)
Corrosion Guard Material:	Glass Reinforced Polyester Compound / PBT
Seal Material:	Standard Thermoset Elastomer
Sealing Gasket Material:	HDPE, Nylon 66 or PTFE
Cable Type:	Steel or Aluminium Wire Armoured Tray and Marine Shipboard Cable
Armour Clamping:	Captive Rotating Cone and Inspectible Cone Ring
Sealing Area:	Inner Sheath, Outer Sheath and total enclosure of gland
Optional Accessories:	Adaptor, Reducer, Locknut and Serrated Washer
Note:	The installer should ensure that the materials are suitable for the installation environment.

Temperature Range

When fitted with sealing gaskets the temperature range for the gland will be:-

Sealing Gasket Material:	Standard Seals: -60°C and +95°C/100°C(HDPE/Nylon Sealing Gasket) Extreme Temp. Seals: -60°C and +160°C (PTFE Sealing Gasket)
--------------------------	---

Standards and Certifications

Equipment Protection Levels:	NEC / CEC: Class I Div 2 Gr ABCD, Class II Div 2 Gr FG Class III Div 2 Ex db IIC Gb, Class I Zone 1 AEx eb IIC Gb / Ex eb IIC Gb Zone 21 AEx ta IIIC Da / Ex ta IIIC Da', Class I Zone 2 AEx nR IIC Gc / Ex nR IIC Gc, 8 IECEx: Ex db IIC Gb, Ex eb IIC Gb, Ex nR IIC Gc, Ex ta IIIC Da	
Conformance:	Standard:	Certifyate:
CEC	CSA C22.2 No. 18.3-12, 174:2018 & 213:2017	E115594
NEC	CSA C22.2 No. 60079 - 0, 1, 7, 15, 31	
IECEx	UL514B, UL121201 UL 60079 - 0, 7, 15, 31	
IP66/68 100m - Parallel	IEC 60529	IEC Ex CML 18.0018X CML 15Y728
Nema Type 4X	NEMA 250	E115594
Deluge Protection	DTS-01	CML 14CA370-2
Corrosion Protection	ASTM B117-11, BS EN ISO 3231	EXOVA N968667
Marine ABS	IEC 60079 - 0, 1, 7, 15, 31 and IEC 60529	ABS 20-SG1952706-PDA
DNV	IEC 60079 - 0, 1, 7 and IEC 60529	TAE0000010
EMC Compatible	EN 55011, + A1, EN 55022	SGS EMC305079/1

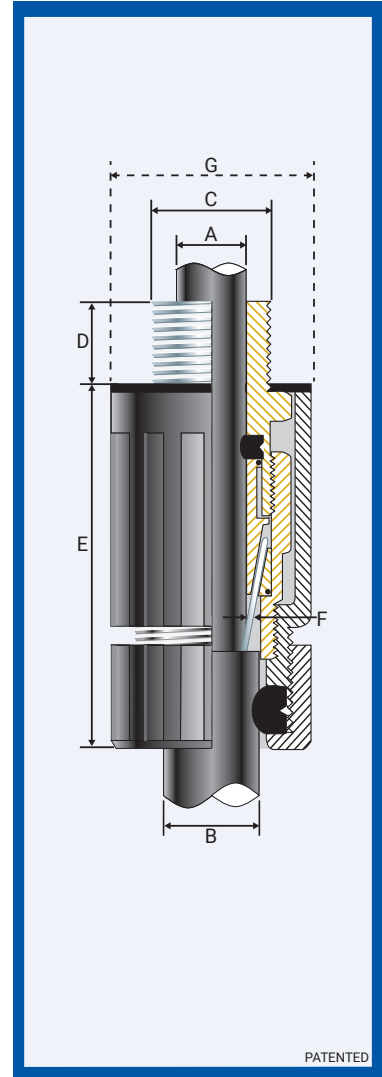

Conditions for Safe Use - X

- The cable glands sizes M20, 3/8" NPT and smaller shall only be used on fixed installations where the cable is clamped, or stress applied to the cable in the gland is prevented.
- According to IEC 60079-14, 10.6.2: An Ex d gland will only maintain Ex d integrity when used with substantially round, compact and filled cable. If not a CCG VORTEX® barrier gland should be used.

Gland Size Ref	Product Code	Entry Thread		Cable Detail				Max Length 'E'	Armour Dia		Max Dia 'G'	Hexagonal Detail		Install. Torque Value Nm/lb ft
		'C'	Min 'D'	Min 'A'	Max 'A'	Min 'B'	Max 'B'		Min 'F'	Max 'F'		Max 'Flats'	Max 'Crns'	
00-20ss	054700-MNA	M20x1.5	0.591	0.118	0.335	0.315	0.531	1.811	0.008	0.035	1.299	0.945	1.063	21/15
0-20s	054701-MNA	M20x1.5	0.591	0.276	0.472	0.453	0.630	1.811	0.008	0.049	1.299	0.945	1.063	21/15
1-20	054701-MNA	M20x1.5	0.591	0.354	0.591	0.571	0.807	2.008	0.008	0.049	1.417	1.063	1.181	21/15
2s-25s	054722-MNA	M25x1.5	0.591	0.433	0.689	0.630	0.965	2.283	0.008	0.063	1.811	1.378	1.535	30/22
2-25	054702-MNA	M25x1.5	0.591	0.551	0.787	0.807	1.043	2.283	0.008	0.063	1.811	1.378	1.535	30/22
3s-32s	054733-MNA	M32x1.5	0.591	0.591	0.866	0.906	1.201	2.638	0.008	0.079	2.087	1.654	1.850	42/31
3-32	054703-MNA	M32x1.5	0.591	0.748	1.043	1.043	1.319	2.638	0.008	0.079	2.087	1.654	1.850	42/31
4s-40s	054744-MNA	M40x1.5	0.591	0.866	1.181	1.555	1.240	2.913	0.012	0.079	2.677	2.047	2.323	52/38
4-40	054704-MNA	M40x1.5	0.591	1.024	1.339	1.299	1.673	2.913	0.012	0.079	2.677	2.047	2.323	52/38
5s-50s	054755-MNA	M50x1.5	0.591	1.142	1.496	1.339	1.870	3.504	0.016	0.098	3.307	2.559	2.874	57/42
5-50	054705-MNA	M50x1.5	0.591	1.339	1.752	1.673	2.067	3.504	0.016	0.098	3.307	2.559	2.874	57/42
6s-63s	054766-MNA	M63x1.5	0.591	1.496	1.969	1.791	2.382	4.016	0.016	0.098	4.331	3.150	3.543	66/49
6-63	054706-MNA	M63x1.5	0.591	1.732	2.224	2.067	2.579	4.016	0.016	0.098	4.331	3.150	3.543	66/49
7s-75s	054777-MNA	M75x1.5	0.591	1.969	2.441	2.244	2.854	4.173	0.016	0.124	4.882	3.780	4.252	72/53
7-75	054707-MNA	M75x1.5	0.591	2.205	2.657	2.579	3.071	4.173	0.016	0.124	4.882	3.780	4.252	72/53
8-80	054708-MNA	M80x2.0	0.787	2.323	2.717	2.559	3.051	4.606	0.098	0.124	4.882	3.780	4.252	80/59
9s-90s	054799-MNA	M90x2.0	0.787	2.598	2.953	2.874	3.406	4.606	0.118	0.138	4.882	4.370	4.921	89/66
9-90	054709-MNA	M90x2.0	0.787	2.913	3.209	3.228	3.583	4.606	0.118	0.138	4.882	4.370	4.921	89/66
10-10	054710-MNA	M100x2.0	0.787	3.189	3.583	3.543	3.937	4.606	0.118	0.138	5.512	4.921	5.551	98/72

All dimensions are in inches.

CCG reserves the right to make alterations to the technical data, dimensions, designs and products available without notice. The illustrations cannot be considered binding. Please contact CCG for assistance.

EXCG-GH010424NA

FITTING INSTRUCTIONS

Metric Illustration

ENCLOSURES AND EQUIPMENT TO WHICH CABLE GLANDS ARE FITTED:-

- Must be made from materials which are compatible with the cable gland materials.
- Have a sealing area around the cable gland entry point with a surface roughness <math>< Ra 6.3 \mu m</math>.
- Have entries that are perpendicular to the enclosure face in the area where the cable gland will seal to within 2.5°.
- Are sealed using the supplied sealing gasket.

MUST HAVE THREADED ENTRIES

- The same thread size as the cable gland. (Thread adapters should be used to correct any mismatch).

- With a thread tolerance of metric class '6H' or equivalent.
 - Where the thread length is a minimum of 10mm for Ex d applications or 3mm for all other applications
- OR CLEARANCE HOLES (not Ex d)**
- Where the hole size is the thread nominal size with a tolerance of +0.1 to +0.7mm. (e.g. the clearance hole for an M20 thread will have a diameter between 20.1mm and 20.7mm).
 - Through material that is between 1mm and 12mm thick. (Thicker materials can be accommodated using glands with extended entry threads).

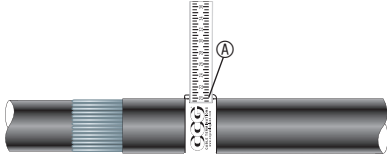

1. For accurate sizing, use a CCG Dimension Tape (A) on the inner and outer cable sheath.

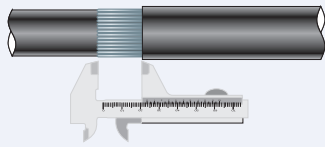

Gland Size	Armour Length	Gland Size	Armour Length	Gland Size	Armour Length	Gland Size	Armour Length
00-16ss	20.0	2-25	25.0	5s-50s	35.0	7-75	50.0
00-20ss	20.0	3s-32s	30.0	5-50	35.0	8-80	50.0
0-20s	20.0	3-32	30.0	6s-63s	45.0	9s-90s	50.0
1-20	25.0	4s-40s	30.0	6-63	45.0	9-90	50.0
2s-25s	25.0	4-40	30.0	7s-75s	50.0	10-100	60.0

2. Cut back the cable outer sheath to expose the armour to a length as per the table above.

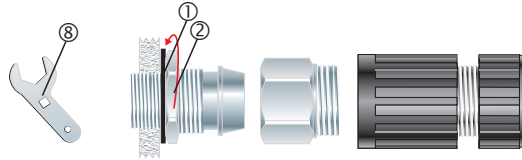

3. To maintain IP66/68 ensure gasket (1) is in place. Screw the inner (2) into apparatus. Tighten the inner (2) to installation torque using a CCG Spanner (8).

Alternative installation through an unthreaded entry.

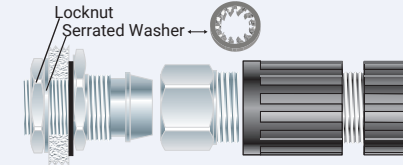

If the apparatus is untapped use a locknut.

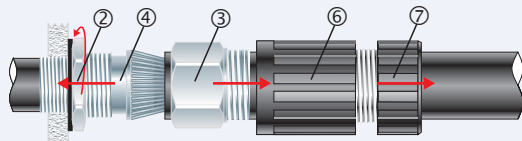

4. Pass the corrosion guard outer nut (7), corrosion guard body (6) and the gland body (3) over the cable. Pass the cable end through the inner (2) and splay the armour wires over the cone (4).

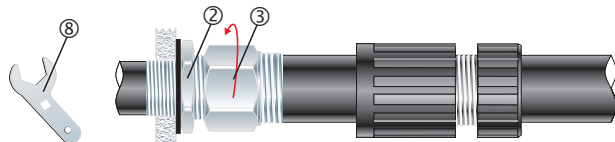

5. Screw the gland body (3) onto the inner (2) and tighten the gland body (3) using a CCG Spanner (8) to lock the armour between the cone (4) and the cone ring (5).

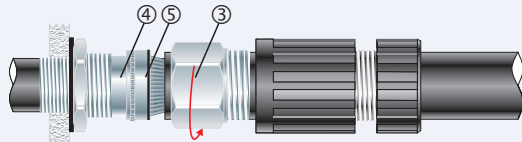

6. Unscrew the body (3). Check that the armour has locked between the cone (4) and the cone ring (5). (O-Ring on the cone ring (5) is sacrificial).

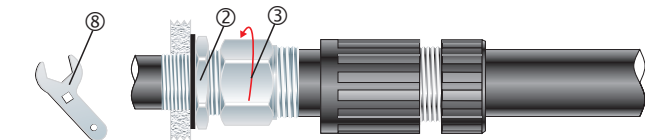

7. Tighten the body (3) onto the inner (2) until hand tight, then tighten with a CCG Spanner (8) with 3/4 turn to lock the armour between the cone (4) and the cone ring (5).

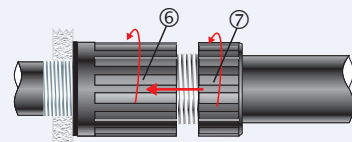

8. Slide corrosion guard body (6) and corrosion guard outer nut (7) over assembled gland, screw corrosion guard body (6) onto the gland. **Hand tighten** corrosion guard body (6) and corrosion guard outer nut (7) to produce the required dust and waterproof seal IP66/68.